

VB-50T-I PRESET TORQUE WRENCH  
 RANGE: 10-50 FT-LBS (13-68 NM)  
 DRIVE SERIES: RJ  
 WEIGHT: 1.30 LBS

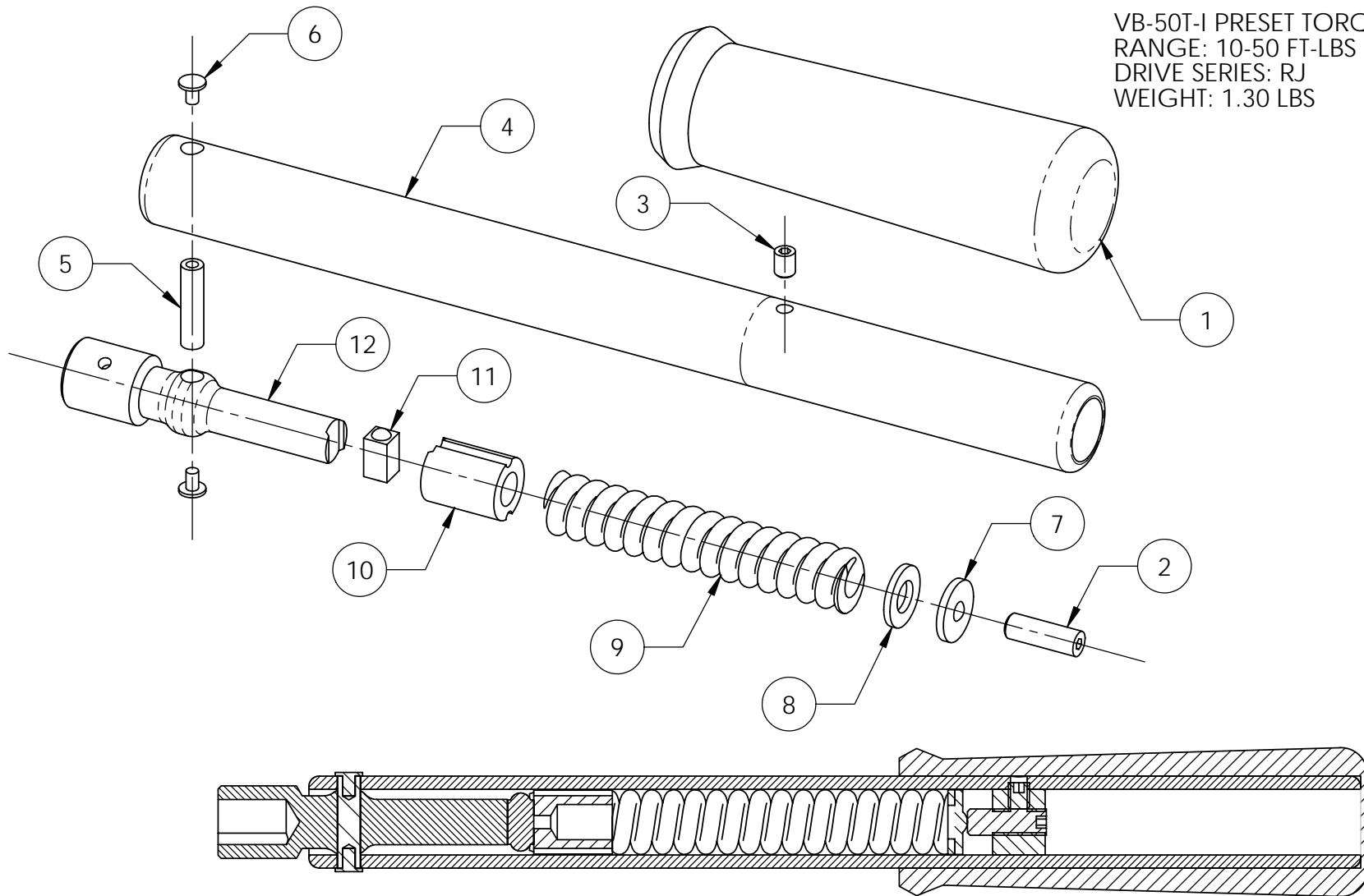

SEE PAGE 2 FOR PART NUMBERS  
 AND DESCRIPTIONS

ADJUSTMENT TOOL PART #: AT-2

PG. 1 OF 2



**Van F. Belknap**

Company, Inc.

Division:

**Hank Thorn**

Company, Inc.

29164 Wall Street / Wixom, Michigan 48393 / Phone: (248)348-7800 / Fax: (248)348-9821

SCALE: 2:3

DATE: 10/28/2005

UNLESS OTHERWISE SPECIFIED:  
 1. ALL DIMENSIONS ARE  $\pm 0.005$   
 2. BREAK ALL SHARP EDGES

DRAWN BY: R.NORTH

APPROVED BY:

DRAWING NUMBER:  
 VB-50T-I

VB-50T-I PRESET TORQUE WRENCH

ITEM	QTY	DESCRIPTION
1	1	30-277-4 - HAND GRIP
2	1	10-101-8 - ADJUSTING SET SCREW
3	1	10-101-34 - LOCKING SET SCREW
4	1	30-500-44 - TUBE ASSEMBLY
5	1	45-91 - PIVOT PIN
6	2	45-92 - PIVOT PIN RIVET
7	1	30-8 - THRUST WASHER
8	1	10-104-1 - FLAT WASHER
9	1	30-11 - TORQUE SPRING
10	1	45-251 - CAM
11	1	45-253-1 - PAWL
12	1	30-5-2 - CLICK ARM

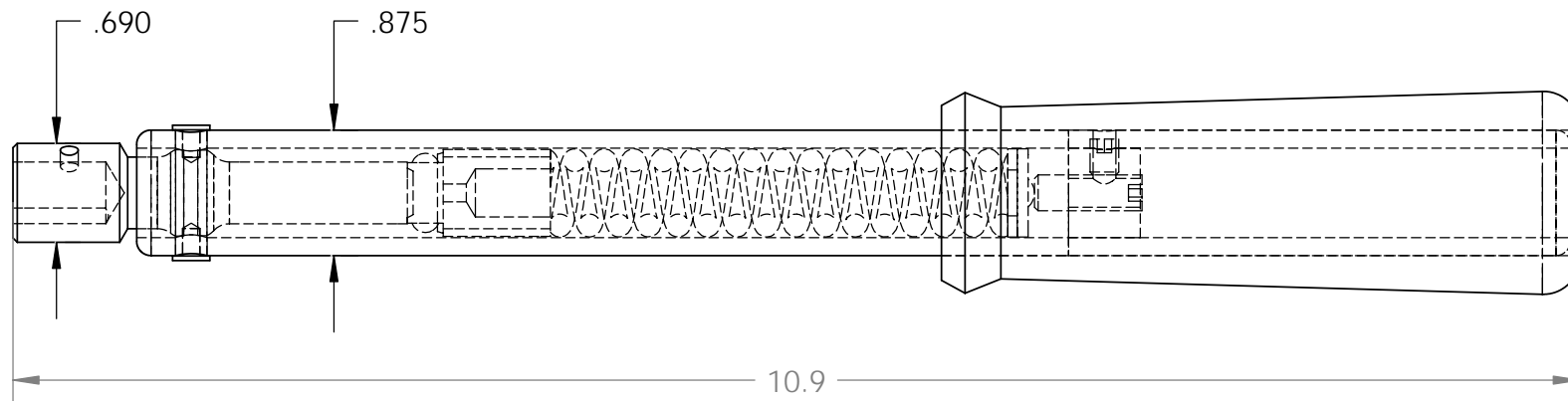

VB-50T-I PRESET TORQUE WRENCH  
 RANGE: 10-50 FT-LBS (13-68 NM)  
 DRIVE SERIES: RJ  
 WEIGHT: 1.30 LBS

PG. 2 OF 2



**Van F. Belknap**

Company, Inc.

Division:

**Hank Thorn**

Company, Inc.

29164 Wall Street / Wixom, Michigan 48393 / Phone: (248)348-7800 / Fax: (248)348-9821

SCALE: 3:4

UNLESS OTHERWISE SPECIFIED:

1. ALL DIMENSIONS ARE  $\pm 0.005$

2. BREAK ALL SHARP EDGES

DRAWN BY: R.NORTH

DATE: 10/28/2005

APPROVED BY:

DRAWING NUMBER:

VB-50T-I PRESET TORQUE WRENCH

VB-50T-I